

Apogeo14



Pubblicazione a cura di
Publication edited by
Direzione marketing Tagina Ceramiche d'Arte

Progetto grafico / Graphic design
33 multimedia Studio

Fotografie / Pictures
Render foto-realistici / Photorealistic 3D
33 multimedia Studio

Stampa / Print
Artegraf

Thanks to:
Dandy Home Collection is a Gamma International Brand

Finito di stampare nel mese di Marzo 2015
Finished ti print in the month of March 2015

INDEX

NEW COLLECTION Apogeo14

STILE CONTEMPORANEO CONTEMPORARY STYLE

04/28/78 ANTHRACITE

18/42 WHITE

22/32 GREY

38 BLACK

FASCINO ANTICO

ANTIQUE CHARM

14 OLD COTTO

34 LIGHT BROWN

54 TORTORA

26/50 DARK BROWN

EFFETTO PIETRA

STONE EFFECT

60/82 GOLDEN

10/44 SUNSET

38 SMALL SPACES

64 DECORI

76 SUGGESTIONS OUTDOOR

86 MINIMALI E DATI TECNICI



STILE MATERICO/MATTER STYLE

ISPIRAZIONE NATURALE/ NATURAL INSPIRATION

UNA COLLEZIONE DI PIASTRELLE IN GRES PORCELLANATO BELLE COME LA NATURA, FORTI COME IL FUOCO, UNICHE COME UN'OPERA D'ARTE. DA SCEGLIERE IN TRE DECLINAZIONI: STILE CONTEMPORANEO, FASCINO ANTICO ED EFFETTO PIETRA PER VESTIRE OGNI AMBIENTE CON UNO STILE INCONFONDIBILE: DALLA PROPRIA CASA A UNO SPAZIO PUBBLICO, DA UN LUOGO ESTERNO AD UN CENTRO BENESSERE.

NEI COLORI E NELLE TRAME APOGEO DI TAGINA RACCHIUDE LA BELLEZZA DEL MONDO NATURALE. PROPOSTA IN 3 SPESSORI: COMPACT IN 18 E 20MM PER ESTERNI E NELLO SPESSORE 10MM UTILIZZABILE ANCHE COME RIVESTIMENTO A PARETE, SI PUÒ SCEGLIERE IN 10 COLORI, CON BELLISSIMI DECORI E IN TANTISSIMI FORMATI TRA CUI L'ESAGONALE, SIA CON BORDO LINEARE CHE "IRREGOLARE".

A COLLECTION OF PORCELAIN TILES BEAUTIFUL AS NATURE, STRONG AS FIRE, UNIQUE AS A WORK OF ART. TO CHOOSE IN THREE DIFFERENT VERSIONS: CONTEMPORARY STYLE, ANTIQUE CHARM, AND STONE EFFECT TO COVER ANY ENVIRONMENT WITH A UNMISTAKABLE STYLE: FROM YOUR OWN HOUSE TO A PUBLIC SPACE, FROM AN OUTDOOR ENVIRONMENT TO A WELLNESS CENTRE.

THE COLOURS AND THE WEAVES APOGEO OF TAGINA CONTAIN THE BEAUTY OF THE NATURAL WORLD. PROPOSED IN 3 THICKNESSES: COMPACT IN 18 AND 20MM FOR OUTDOOR AND 10MM THICKNESS THAT CAN BE EMPLOYED ALSO FOR WALLS COVERING, CAN BE SELECTED IN 10 COLOURS, WITH VERY BEAUTIFUL DECORS AND A LOT OF SIZES INCLUDING THE HEXAGON ONE, BOTH WITH LINEAR AND IRREGULAR EDGE.



STILE CONTEMPORANEO CONTEMPORARY STYLE

SEGUENDO LE ULTIME TENDENZE / FOLLOWING THE LAST TENDENCIES

Nei colori più neutri, per abbinarsi ed esaltare gli arredi e le finiture di ambienti contemporanei: eleganza minimale, senza perdere il fascino della materia.

With more neutral colours, to match and exalt the furniture and the finishes of contemporary living spaces: minimal elegance, without losing the charm of matter.

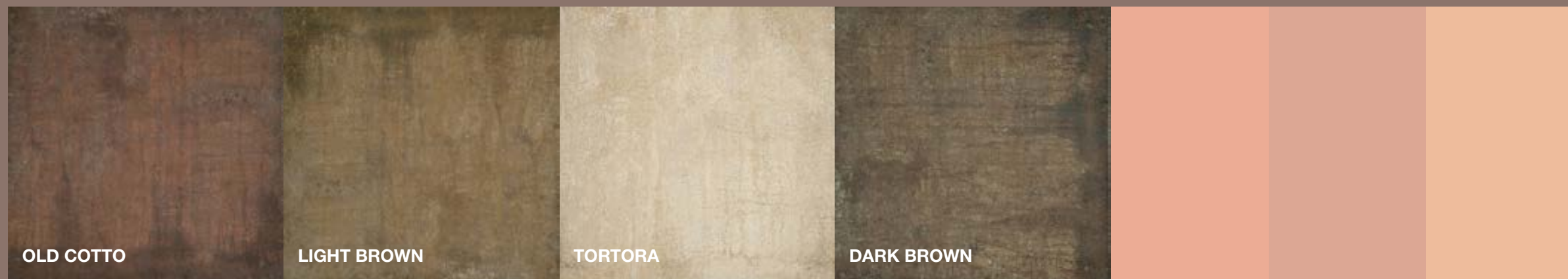

FASCINO ANTICO ANTIQUÉ CHARM

CLASSICO SEMPRE ATTUALE / CLASSIC STILL UP_TO_DATE

Interpretazione degli ambienti con colori caldi, densi ma sempre attuali: per completare gli arredi in stile classico o dare un tocco di calore a quelli più contemporanei.

Interpretation of the environments with warm colours, dense but always modern: to complete the furnishings in classical style or give a touch of warmth to the contemporary ones.



EFFETTO PIETRA STONE EFFECT

LA MATERIA DIVENTA VIVA / MATTER BECOMES ALIVE

Nei colori della pietra, due sfumature vibranti e vitali che illuminano gli arredi ed esaltano le architetture di ogni ambiente. Una scelta perfetta soprattutto nei tagli di grandi dimensioni.

In the stone colours, two vibrant and vital ones that enlighten the furnishings and exalt the architectures of any environment. A perfect choice especially in the big sizes..



THE CONTEMPORARY STYLE

APOGEO14 ANTHRACITE



no°
9

BOUTIQUE

COME CREARE IL PROPRIO STILE
HOW TO CREATE YOUR OWN STYLE

La soluzione ideale per creare ambienti aperti al pubblico, come Boutique e attività commerciali in genere: elegante e non invadente, perfettamente abbinabile agli arredi contemporanei e classici, ne completa e caratterizza lo stile, resistendo all'usura del tempo.

The best solution to create open public environments, as Boutique and commercial activities in general: elegant and not intrusive, perfectly matchable with contemporary and classic furnishings, completes and characterizes the style, resisting to timeworn.





Apogeo14

BOUTIQUE

APOGEO14 / ANTHRACITE 46x92 fondo



no°

LIVING

EMOZIONI DA VIVERE OGNI GIORNO
EMOTIONS TO LIVE EVERYDAY

Il colore Sunset dona alla casa la forza e il calore della materia naturale: è in sintonia con gli arredi grazie alle sfumature cromatiche equilibrate.

The Sunset color gives to the house the strength and the warmth of the natural matter: it's in syntony with the furnishings thanks to the balanced chromatic nuances.

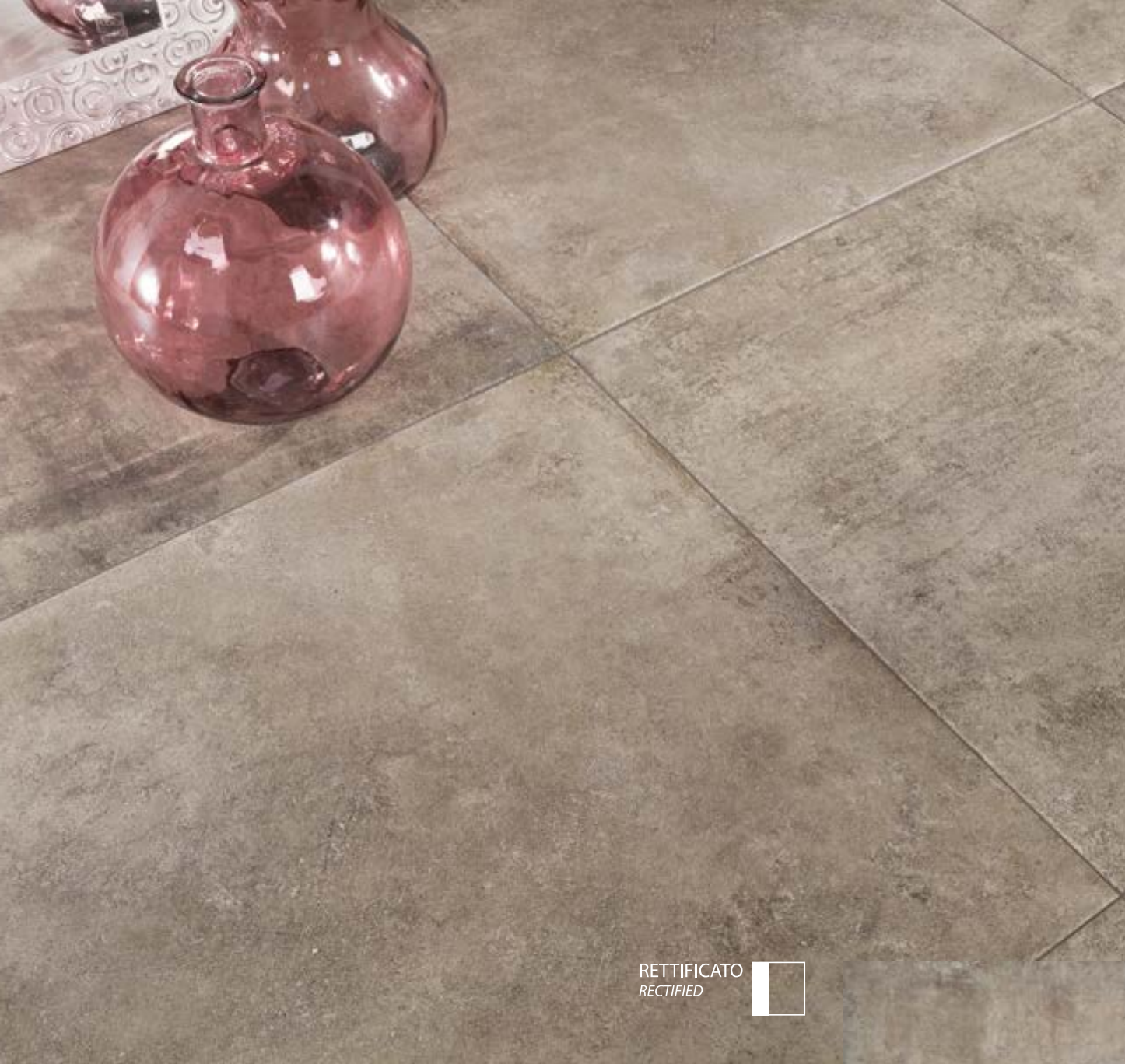

RETTIFICATO
RECTIFIED



Apogeo14

APOGEO14/SUNSET 90x90 fondo rettificato

APOGEO14/SUNSET 92x92 fondo /5x60/10x60/15x60 fondo



NATURALE
NATURAL





BISTRO

NEI LUOGHI DELL'ACCOGLIENZA
IN THE RECEPTION PLACES

Scelta ideale per i locali pubblici, l'Old Cotto è stato creato per stare in mezzo alla gente e donare calore e accoglienza.

Best choice for public places the Old Cotto has been created to be together with the people and give warmth and welcome.





Apogeo14

BISTRO

APOGEO14/OLD COTTO 22.5x90 fondo rettificato



no°
01

SPA

PROGETTO BENESSERE WELLNESS PROJECT

Rivestimenti progettati per resistere all'umidità e al calore, realizzati sapientemente per essere usati ogni giorno: proposti in finiture naturali e armoniose, ideali per gli ambienti dedicati al benessere e all'accoglienza

Wall tiles made to resist to humidity and to the heat, wisely made to be used on daily basis: proposed in natural and in harmonious finishes, ideal for environments dedicated to the wellness and reception.





FONDO
RIGATINO



FONDO
RIGATINO

Apogeo14!

SPA

APOGEO14/WHITE 45x90 f. rett./22.5x90 f. rett./22.5x90 f. rett. rigatino
APOGEO14/WHITE 45x90 fondo rett./22.5x90 fondo rettificato





BAGNO

PER OGNI AMBIENTE DELLA TUA CASA
FOR ANY ENVIRONMENT OF YOUR HOME

La collezione Apogeo, perfetta per pavimenti e rivestimenti, completa l'arredo della stanza da bagno, esaltandone le finiture e lo stile.

The collection Apogeo, perfect for floors and walls covering, completes the furnishing of the bathroom, exalting the finishes and the style.





NATURALE
NATURAL



BAGNO

APOGEO14/GREY 92x92 fondo

APOGEO14/GREY 90x90 fondo rettificato



Apogeo14



RETTIFICATO
RECTIFIED





Apogeo14

BAGNO

APOGEO14/DARK BROWN L.19,5 esagona fiore a rilievo

APOGEO14/DARK BROWN 45x90 fondo rettificato



APOGEO14/ANTHRACITE 90x90 fondo rett./30x90 fondo rett./ 30x90 f. rigatino rett.

APOGEO14/WHITE 30x90 fondo rettificato / 30x90 fondo rigatino rett.



Apogeo14

APOGEO14/ANTHRACITE 30x90 fondo rett./ 30x90 f. rigatino rett.

APOGEO14/WHITE 30x90 fondo rettificato / 30x90 fondo rigatino rett.



Apogeo14

APOGEO14/GREY 22,5x90 fondo rett. / fondo rigatino rett. / 30x90 fondo rett.



ARTICOLO CUSTOMIZZATO
disponibile su richiesta.
CUSTOM ITEM
available by request.

no°



INGRESSO ENTRANCE

INVITO A QUALCOSA DI SPECIALE
INVITATION TO SOMETHING SPECIAL

Anche per le zone di passaggio, permette una continuità di stile
e apre a soluzioni creative ed eleganti.

*Also for the doorway areas, allows a continuity in the style and
opens to creative and elegant solutions.*



NATURALE
NATURAL



INGRESSO

APOGEO14/LIGHT BROWN 61x61 fondo

APOGEO14/LIGHT BROWN 60x60 fondo rett./7.5x60 battiscopa rettificato



Apogeo14

RETTIFICATO
RECTIFIED





SMALL SPACES





Apogeo14

APOGEO14/BLACK 61x61 fondo/7.5x61 battiscopa

Apogeo14



APOGEO14/WHITE 90x90 fondo rett./30x60 fondo rett./10x10 Deco Perlage Deco mix

Apogeo14

APOGEO14/SUNSET 30,5x61 fondo



Apogeo14



APOGEO14/GREY 30x60 fondo rett.

THE RUSTIC STYLE

APOGEO14 OLD COTTO



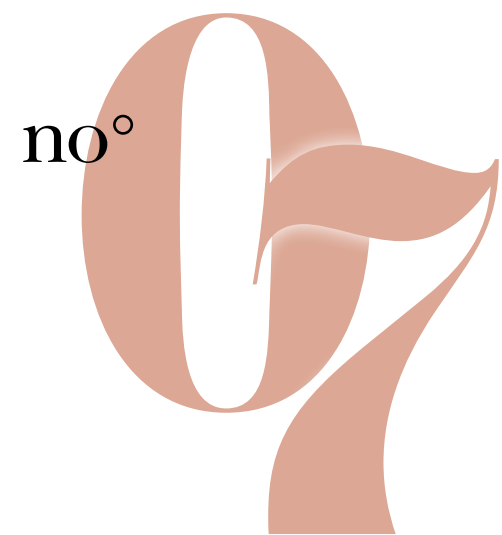

ZONA BRUNCH BRUNCH ZONE

ARREDARE GLI SPAZI DELLA QUOTIDIANITÀ
FURNISH THE DAILY LIVING SPACES

Il Gres porcellanato non solo veste con eleganza ogni stanza completando l'arredamento, ma è funzionale e robusto all'usura, ideale per i luoghi della casa più vissuti

The glazed porcelain not only covers with elegance each room completing the furnishing, but it's functional and sturdy to the wear, ideal for the most frequented places of the house.





Apogeo14

ZONA BRUNCH

APOGEO14/DARK BROWN 61x61 fondo



no°



MANSARDA

PER OGNI STILE, IL FASCINO APOGEO
FOR ANY STYLE, THE APOGEO CHARM

Ogni ambiente acquista fascino: seguendo i tuoi gusti e il tuo stile,
Tagina ha la soluzione mirata per ogni stanza della tua casa.

*Every environment gains charm: following your taste and style,
Tagina has the right solution for every room of your house.*



Apogeo14

MANSARDA

APOGEO14/TORTORA 35x35 fondo/17.25x35 fondo/17.25x17.25 fondo





Apogeo14

APOGEO14/OLD COTTO 17,25x35 fondo



APOGEO14/LIGHT BROWN 35x35 fondo/17,25x35 fondo/17,25 x 35 bordura Lobi a rilievo colorato marrone

Apogeo14



APOGEO14/GOLDEN 35x35/17,25x35/17,25x17,25 fondo

Apogeo14



APOGEO14/TORTORA L. 19.5 Esagona in tinta/esagona fiore a rilievo

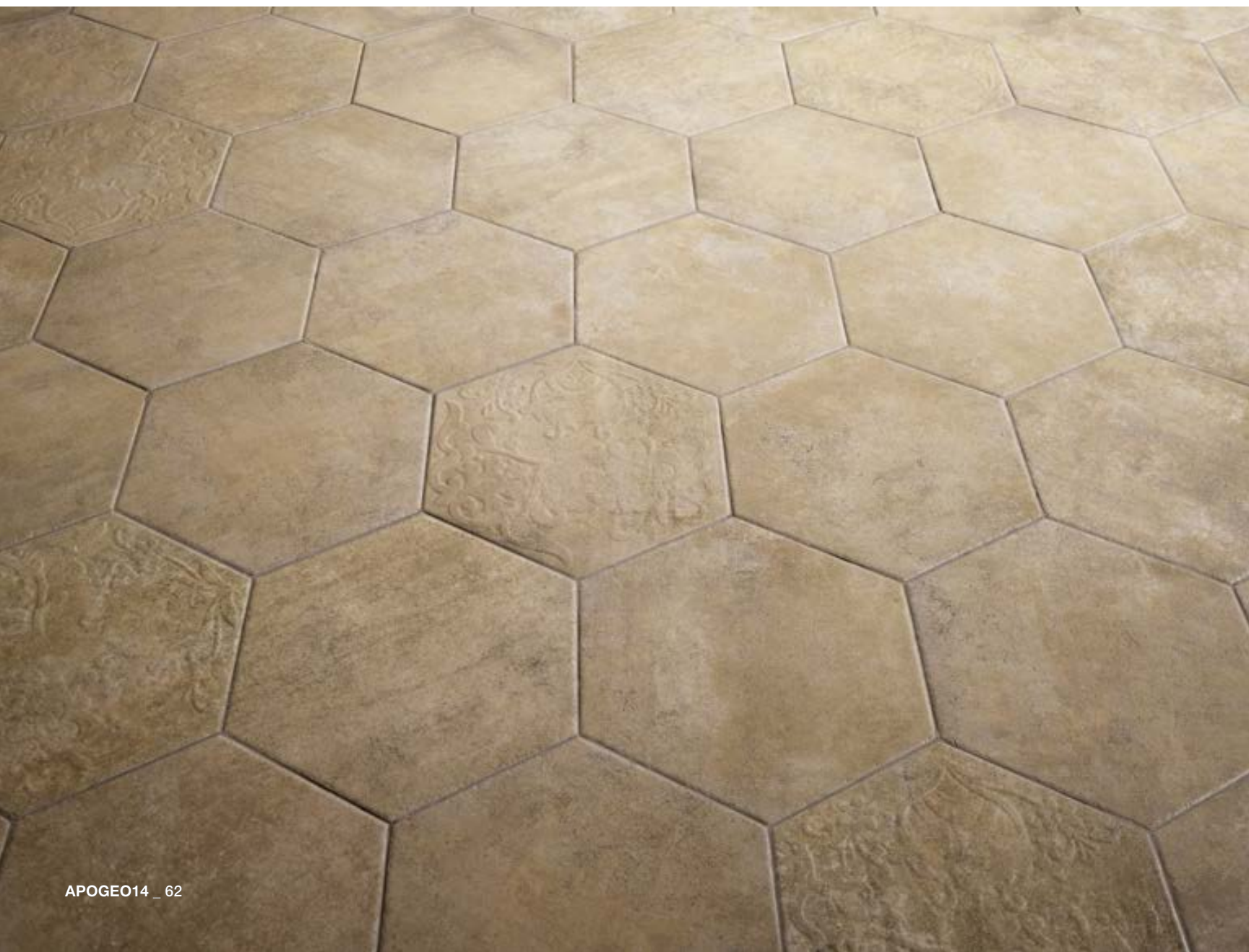

APOGEO14/OLD COTTO L. 19.5 Esagona in tinta/esagona fiore a rilievo

DECORI/DECORS





Apogeo14

APOGEO14/DARK BROWN

35x35 fondo/17,25x17,25 fondo/ 17,25x35 Bordura Lobi a rilievo colorato marrone



APOGEO14/DARK BROWN

35x35 fondo/17,25x17,25 fondo
17,25x35 Bordura Lobi a rilievo colorato marrone
35x35 Rosone a rilievo colorato marrone
35x35 Fascia Lobata a rilievo colorato marrone
35x35 Ang. Rosone a rilievo colorato marrone

Apogeo14

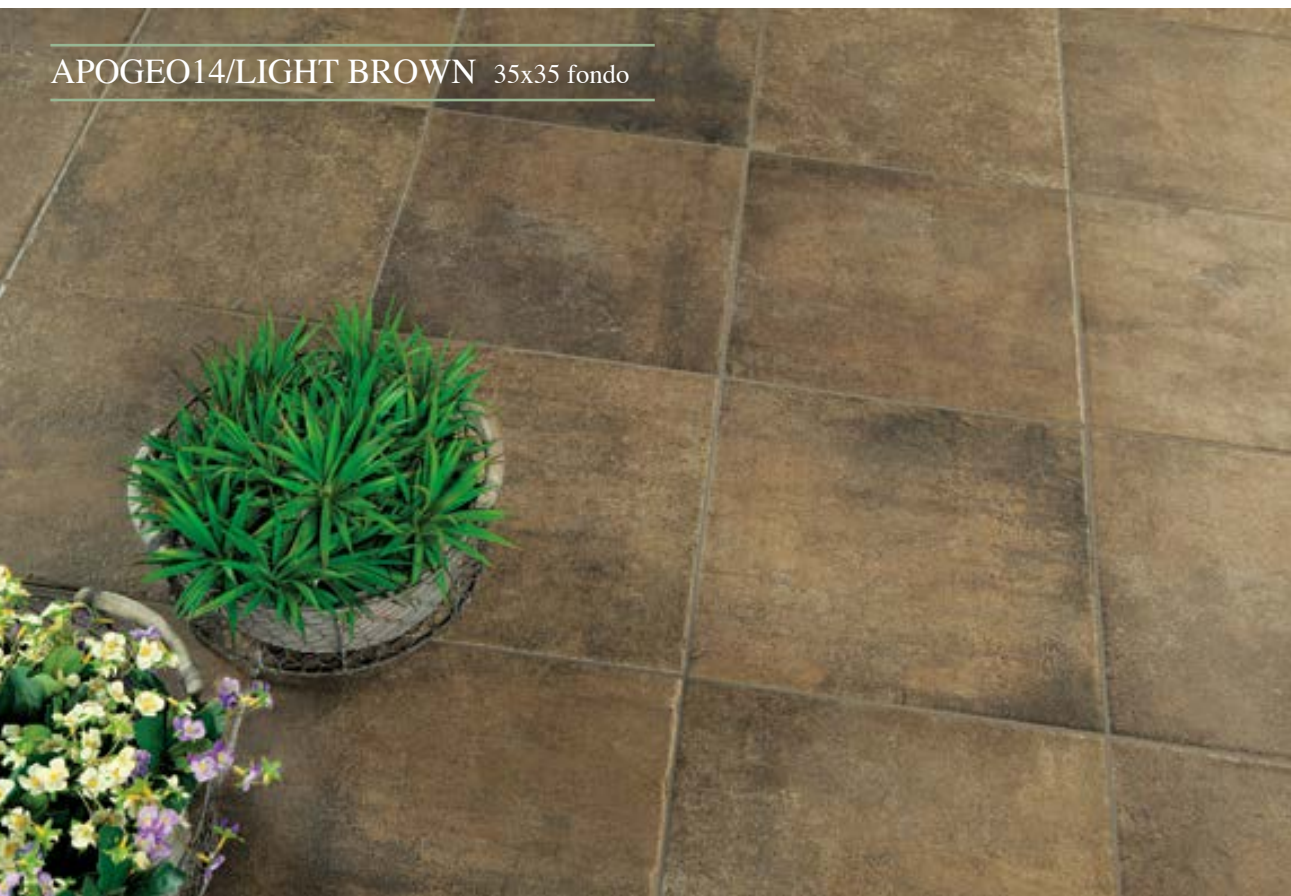

APOGEO14/LIGHT BROWN 35x35 fondo



APOGEO14/LIGHT BROWN 35x35 fondo/17.25x35/17.25 x 35 bordura Lobi a rilievo colorato marrone



Apogeo14



APOGEO14/TORTORA

35x35 fondo/17.25x35 Bordura Lobi a rilievo colorato azzurro
17.25x17.25 Bordura Lobi a rilievo colorato azzurro
35x35 Ang. Rosone a rilievo colorato azzurro.
7.5x61 battiscopa



Comp. tappeto cm 70x140 (8 pz 35x35):
35x35 Angolo Rosone/35x35 Fascia Lobata



Comp. tappeto cm 70x70 (4 pz 35x35):
35x35 Angolo Rosone

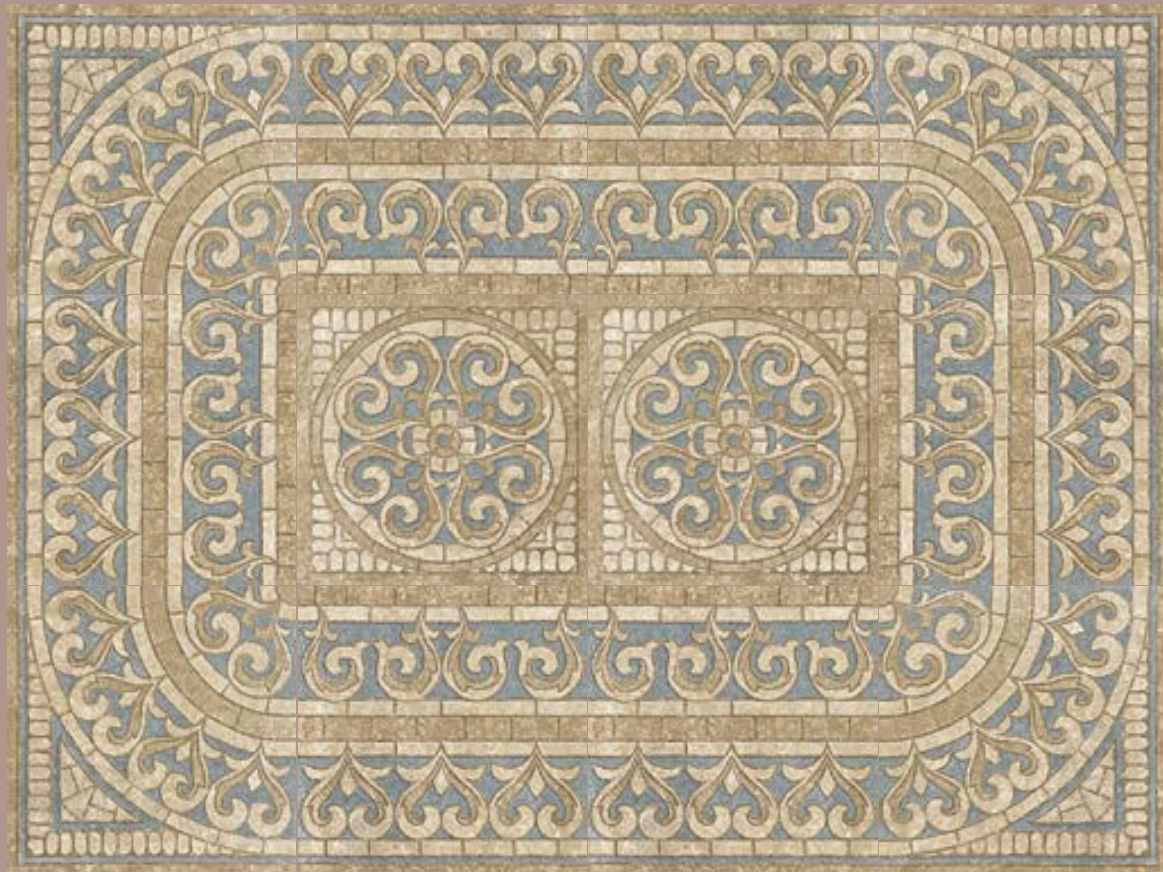

Comp. tappeto cm 105x140 (12 pz 35x35):
35x35 Angolo Rosone/35x35 Fascia Lobata/35x35 Rosone



Comp. tappeto cm 105x105 (9 pz 35x35):
35x35 Angolo Rosone/35x35 Fascia Lobata/35x35 Rosone

DECORI "COLORATI"/"COLOURED" DECORS



DECORO A RILIEVO COLORATO
COLOURED RELIEF DECOR



DECORO PIANO COLORATO
COLOURED PLAIN DECOR



DECORO A RILIEVO IN TINTA
PLAIN COLOURED RELIEF DECOR

AZZURRO (2Q)



35x35
Angolo Rosone piano colorato 8BD**AP
Angolo Rosone rilievo colorato 8BD**AR



35x35
Fascia Lobata piana colorata 8BD**FP
Fascia Lobata a rilievo colorata 8BD**FR



35x35
Rosone piano colorato 8BD**RP
Rosone a rilievo colorato 8BD**RR



17,25x35
Bordura Lobi piana colorata 8BD**BP
Bordura Lobi a rilievo colorata 8BD**BR



17,25x17,25
Ang. Lobi piano colorato 8BD**NP
Ang. Lobi a rilievo colorato 8BD**NR

MARRONE (M1)



VERDE (18)



ROSSO (07)



DECORI "IN TINTA"/"PLAIN COLOUR" DECORS

GREY (06)



35x35
Angolo Rosone a rilievo in tinta 8BD**AR



35x35
Fascia Lobata a rilievo in tinta 8BD**FR



35x35
Rosone a rilievo in tinta 8BD**RR



17,25x35
Bordura Lobi a rilievo in tinta 8BD**BR



17,25x17,25
Ang. Lobi a rilievo in tinta 8BD**NR

- Old Cotto (41)
- Anthracite (10)
- Black (14)
- Tortora (5E)
- White(08)
- Grey (06)
- Sunset(SU)
- Golden(F7)
- Dark Brown (8J)
- Light Brown (57)



SUGGESTIONS OUTDOOR

COMPACT
ALTO SPESSORE
HIGH THICKNESS



no°

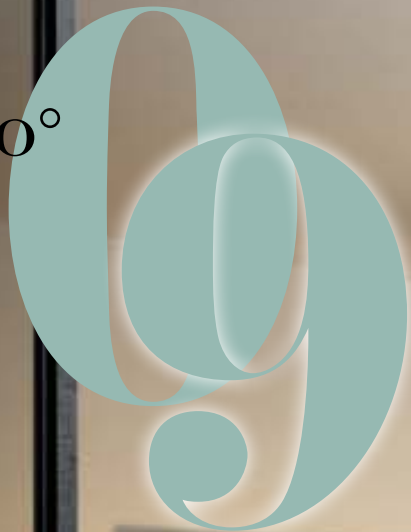

PORTICO PORCH

SOLUZIONE DI CONTINUITÀ
A SOLUTION OF CONTINUITY

Materiali sicuri e affidabili, lavorati secondo la tradizione artigiana, resistenti a qualsiasi clima, per arredare gli esterni in sintonia con gli spazi interni.

Safe and reliable materials, manufactured according to the artisan tradition, resistant to any weather condition to furnish the outdoor in syntony with the indoor living spaces.



IN / OUT



COMPACT
ALTO SPESSORE
HIGH THICKNESS





46x92
30x50
45x90
90x90
92x92
COMPACT

COMPACT
ALTO SPESSORE
HIGH THICKNESS



Apogeo14

PORTICO

APOGEO14/ANTHRACITE 45x90 fondo compact rett./90x90 fondo rett./5x60/10x60/15x60 fondo



no°
10

ESTERNO OUTDOOR

SOTTO QUALSIASI CIELO
UNDER ANY SKY

Pavimenti pensati per valorizzare gli esterni: finiture classiche o contemporanee si armonizzano con lo stile di giardini e piscine e resistono perfettamente a ogni temperatura

Floor tiles studied to value the outdoors: classical or contemporary finishes are harmonized with the garden or swimming pools style and resist perfectly to any temperature.



POSA SU GHIAIA E SABBIA
LAYING ON GRAVEL AND SAND

Apogeo14

POOL GARDEN

APOGEO14/GOLDEN 92x92 fondo compact

APOGEO14/GOLDEN 61x61 fondo compact/61x61 fondo/7.5x61 battiscopa





PEZZI SPECIALI / SPECIAL PIECES

APOGEO14 ANTHRACITE 61x61 Gradino BNose 1-2 lati/46x92 fondo compact/46x92 fondo



APOGEO14/WHITE 61x61 fondo compact/20x30 stone drip



APOGEO14/GRAY 92x92 fondo/61x61 gradino BNose 1 e 2 lati/7,5x61 battiscopa

SISTEMI DI POSA / LAYING SYSTEM



POSA TRADIZIONALE
STANDARD LAYING

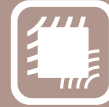

POSA SU GHIAIA E SABBIA
LAYING ON GRAVEL AND SAND



POSA SOPRAELEVATA
RAISED LAYING



POSA SU ERBA
LAYING ON GRASS



AVVERTENZE PER POSA SOPRAELEVATA / NOTICE FOR RAISED FLOORS LAYING

Per mantenere i più alti standard qualitativi e garantire una sopraelevazione della piastrella in completa sicurezza, si raccomanda nella posa l'impiego dei piedini supplementari come illustrato nel prospetto seguente:

To maintain the highest quality standards and guarantee the complete safe raising of the tile, we recommend in the laying operations the employment of supplementary supports as illustrated in the following prospect:

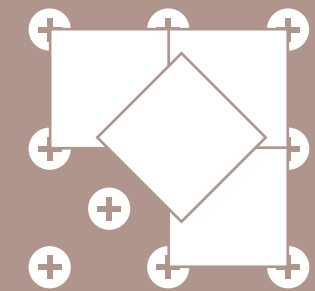
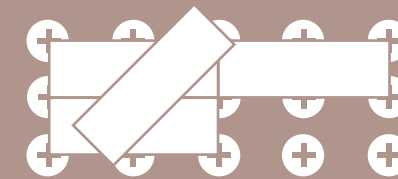
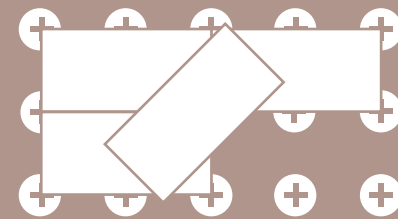
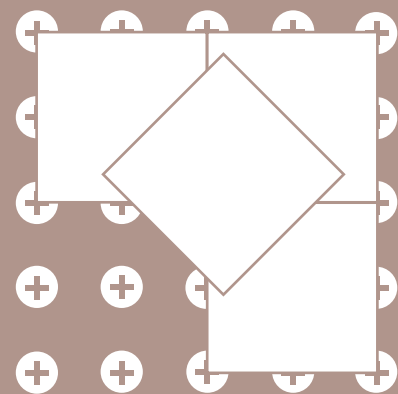

FORMATO	H: 0÷10 CM	H: >10 CM
92x92 36"1/4x36"1/4 compact 18 mm	9 PIEDINI SUPPORTS (1 centrale / 1 in the centre)	* Ufficio Tecnico Tagina

FORMATO	H: 0÷10 CM	H: >10 CM
46x92 18"1/8x36"1/4 compact 18 mm	6 PIEDINI SUPPORTS	* Ufficio Tecnico Tagina
45x90 17"11/16x35"7/16		

FORMATO	H: 0÷10 CM	H: >10 CM
30x90 11"13/16x35"7/16 compact 18 mm	6 PIEDINI SUPPORTS	* Ufficio Tecnico Tagina

FORMATO	H: 0÷2 CM	H: >2÷10 CM	H: >10 CM
61x61 24"3/16x24"3/16 compact 20 mm	4 PIEDINI SUPPORTS	5 PIEDINI SUPPORTS (1 centrale / 1 in the centre)	* Ufficio Tecnico Tagina
60x60 23"5/8x23"5/8			

*Per informazioni concernenti specifiche tecniche relative agli impieghi contrassegnati rivolgersi all'Ufficio Tecnico di Tagina Ceramiche d'Arte Tel.075/9147205

*For information regarding technical specifications relevant to the employments mentioned, please apply to the Technical Office of Tagina Ceramiche d'Arte 0039 075/9147205

SISTEMI DI POSA SOPRAELEVATA / RAISED PAVING SYSTEM

Le lastre di finitura Compact si distinguono per l'elevata resistenza allo scivolamento, l'ottima durata nel tempo e l'inalterabilità strutturale in qualsiasi condizione climatica. Il sistema di pavimentazione sopraelevato prevede l'utilizzo di supporti portanti in polipropilene di tipo fisso, regolabile e autolivellante. Il sistema sopraelevato da esterno, con le fughe aperte, consente un facile deflusso dell'acqua piovana evitando ogni rischio di accumolo della stessa. La posa sopraelevata permette il passaggio di impianti di cablaggio e tubazioni strutturali attraverso una pratica fruizione dell'intercapedine tra il piano posato e il piano di supporto. Le lastre sono posabili a secco anche su sabbia, ghiaia, o erba.

The slabs with the Compact finish differs for the very high anti slip resistance, long-lasting and structural unalterability in any climate condition. The raised paving system is provided with the use of bearing supports in polypropylene fixed or adjustable and auto-levelling. The raised paving system for exterior, with open joints, facilitates an easy draining of rainwater avoiding any risk of build-up of the same. The raised laying allows the passage of wiring and piping systems through a practical fruition of the air space between the laid level and the bottom level. The slabs can be laid without any adhesive also on sand, gravel or grass.

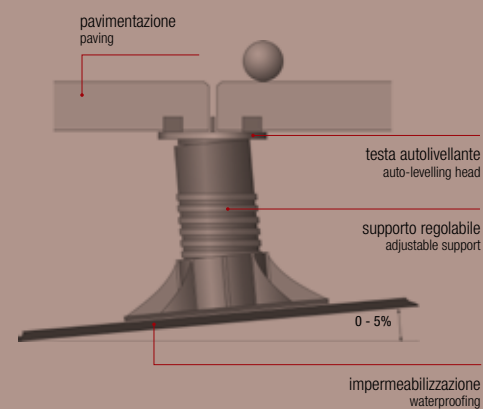

I VANTAGGI DEL SISTEMA SOPRAELEVATO / THE ADVANTAGES OF A RAISED PAVING SYSTEM



L'indipendenza della posa dai relativi supporti garantisce un ottimo assorbimento dei movimenti strutturali.
The independence of the laying from the relative supports can guarantee an excellent absorption of structural movements.



Il sistema sopraelevato non necessita del massetto in calcestruzzo. Tale sistema garantisce una consistente diminuzione del peso sulla struttura portante.
The raised system doesn't need any concrete screed coat. Such system guarantees a consistent decrease of weight on the supporting structure.



Le fughe tra le piastrelle consentono un efficace deflusso dell'acqua.
The joints between the tiles allow a effective draining of water.



La presenza dell'intercapedine tra la pavimentazione sopraelevata e il piano d'appoggio sottostante favorisce un costante passaggio d'aria, favorendo una maggiore impermeabilizzazione ed un elevato isolamento termico.
The presence of the air space between the raised paving and the bottom level allows a constant passage of air favouring a better impermealization and a very high thermal isolation.

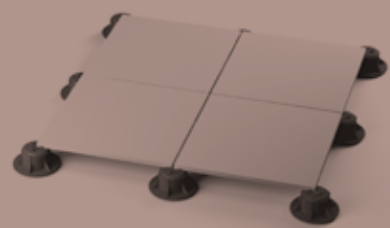

LA GAMMA COMPLETA / THE COMPLETE RANGE

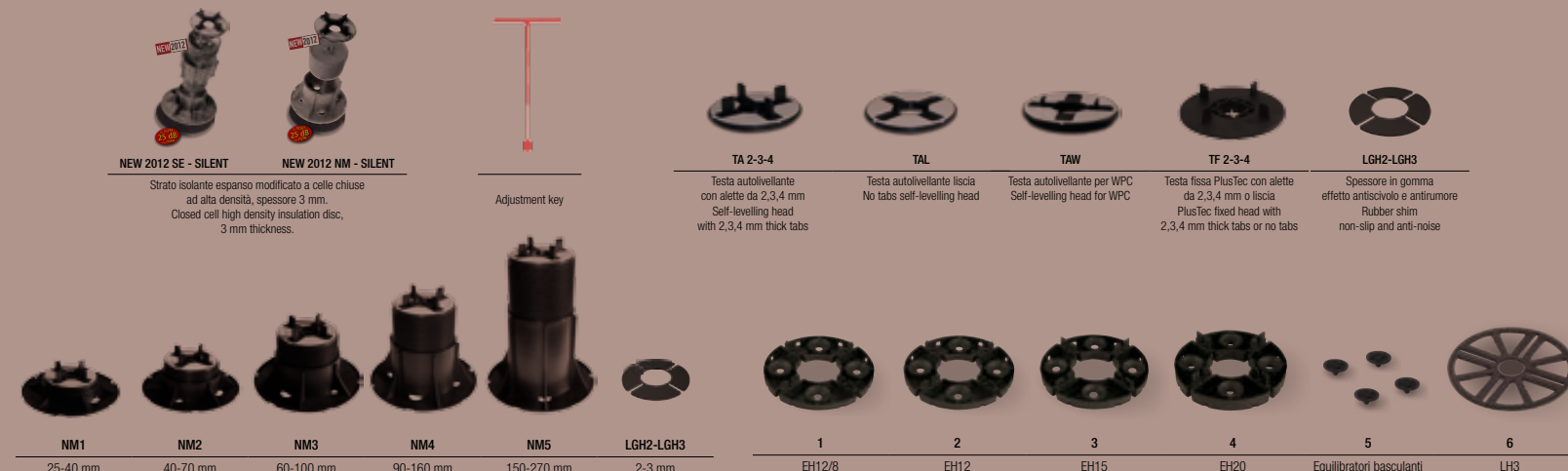

Supporto regolabile "NEW-MAXI" con testa fissa rotante livellatore in gomma LGH2 e LGH3
Adjustable support "New-Maxi" with rotating fixed head with rubber leveller LGH2 and LGH3

Supporto EH12 - EH15 - EH20 equilibratore basculante disco livellatore LH3
Support EH12 - EH15 - EH20 with balancing levelling disk LH3



Supporto regolabile "Eterno" con testa autolivellante / Adjustable support "eterno" with auto-levelling head

CLIP BORDO VERTICALE / CLIP FOR VERTICAL CLOSURE

L'innovazione sicura per 'chiudere in bellezza'

Progettata per far fronte ad un problema comune a tante pavimentazioni esterne, ovvero il tamponamento del bordo quando si è in assenza del muro perimetrale, la clip bordo verticale costituisce un innovativo sistema che permette di chiudere facilmente ed elegantemente lo spazio perimetrale che si crea in presenza di pavimentazioni sopraelevate. Una soluzione composta di due particolari clips in acciaio inox che, messe sopra la testa e sotto la base del supporto Eterno Ivica, creano una sede con dei mordenti che incastrano la porzione di pavimentazione rifilata a misura dello spazio da tamponare, evitando in modo contestuale lo scivolamento delle piastre orizzontali grazie al blocco posto all'estremità della clip bordo pavimento.

The sure new way of finishing in style

Our clip for vertical closure is designed to solve a problem typical of many external floors, i.e. how to fill in the gap around the edge when no perimeter wall is present. This solution represents an innovative, easy and elegant way to eliminate gaps around raised floors. The system consists of two special, stainless steel clips for positioning over the head and under the base of the Eterno Ivica support. It creates a firm seat capable of gripping the section of floor cut to size to fill the gap. The use of our floor edge clip effectively prevents horizontal movement in floor slabs.

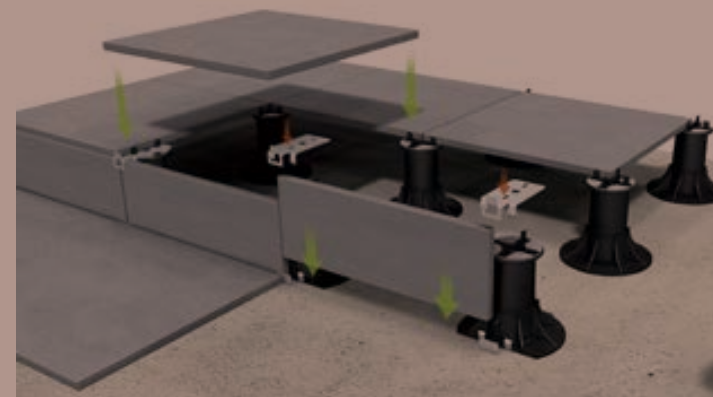

CLIP BORDO PIASTRA / UNIVERSAL EDGE CLIP

La congiunzione ideale tra estetica e funzionalità

Ideata da Eterno Ivica per evitare il contatto tra piastre e muro perimetrale nelle pavimentazioni sopraelevate da esterno, la clip bordo piastra, costruita interamente in acciaio inox, è dotata di ammortizzatore per le dilatazioni longitudinali e trasversali e di un sicuro aggancio per consentire una fuga perimetrale lineare ed elegante, conferendo al contempo stabilità alla pavimentazione..

The perfect join: attractive and functional

Designed by Eterno Ivica to avoid contact between the slabs of outdoor raised floors and outside walls, the universal edge clip is made entirely from stainless steel. It incorporates a damper to absorb longitudinal and transverse thermal expansion and guarantees a secure grip. Use of these clips ensures a stable floor surface with a straight and elegant perimeter.



ANTHRACITE (IO) FORMATI / SIZES

Gres Porcellanato / Porcelain Tiles 10 mm



92x92 - 90x90 / 36¹¹/₁₆ x 36¹¹/₁₆ - 35⁷/₁₆ x 35⁷/₁₆
 92x92 fondo 8BFIO92
 90x90 fondo rett. 8BFIO90
 90x90 fondo rigatino rettificato 8BFIO90/G



46x92 - 45x90
 18¹/₈ x 36¹/₄ - 17¹¹/₁₆ x 35⁷/₁₆
 46x92 fondo 8BFIO42
 45x90 f. rett. 8BFIO49
 45x90 f. rigatino rett. 8BFIO49/G



30x90
 11¹³/₁₆ x 35⁷/₁₆
 fondo rett. 8BFIO39
 f. rigatino rett. 8BFIO39/G

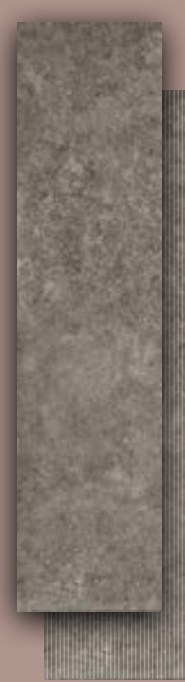

22,5x90
 8⁷/₈ x 35⁷/₁₆
 fondo rett. 8BFIO29
 f. rigatino rett. 8BFIO29/G

WHITE (08) FORMATI / SIZES

Gres Porcellanato / Porcelain Tiles 10 mm



92x92 - 90x90 / 36¹¹/₁₆ x 36¹¹/₁₆ - 35⁷/₁₆ x 35⁷/₁₆
 92x92 fondo 8BF0892
 90x90 fondo rett. 8BF0890
 90x90 fondo rigatino rettificato 8BF0890/G



46x92 - 45x90
 18¹/₈ x 36¹/₄ - 17¹¹/₁₆ x 35⁷/₁₆
 46x92 fondo 8BF0842
 45x90 fondo rett. 8BF0849
 45x90 f. rigatino rett. 8BF0849/G



30x90
 11¹³/₁₆ x 35⁷/₁₆
 fondo rett. 8BF0839
 f. rigatino rett. 8BF0839/G



22,5x90
 8⁷/₈ x 35⁷/₁₆
 fondo rett. 8BF0829
 f. rigatino rett. 8BF0829/G



61x61 - 60x60
 24³/₁₆ x 24³/₁₆ - 23⁵/₈ x 23⁵/₈
 fondo 8BFIO61
 fondo rett. 8BFIO60



30,5x61 - 30x60
 12¹/₂ x 24³/₁₆
 11¹³/₁₆ x 23⁵/₈
 30,5x61 fondo 8BFIO36
 30x60 fondo rett. 8BFIO63



15x60 / 5⁷/₈ x 23⁵/₈
 fondo 8BFIO65



10x60 / 3¹⁵/₁₆ x 23⁵/₈
 fondo 8BFIO16



5x60 / 1¹⁵/₁₆ x 23⁵/₈
 fondo 8BFIO56



7,5x61 - 7,5x60
 2¹⁵/₁₆ x 24³/₁₆ - 2¹⁵/₁₆ x 23⁵/₈
 battiscopa 8BDIOBA
 battiscopa rett. 8BDIOBA/R

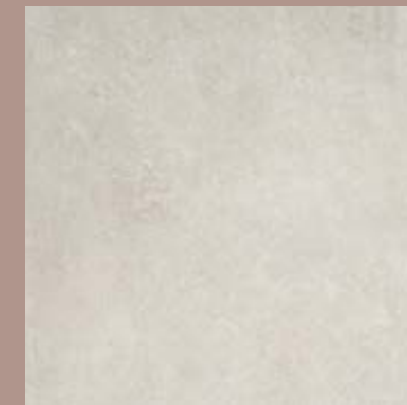

61x61 - 60x60
 24³/₁₆ x 24³/₁₆ - 23⁵/₈ x 23⁵/₈
 fondo 8BF0861
 fondo rett. 8BF0860



30,5x61 - 30x60
 12¹/₂ x 24³/₁₆
 11¹³/₁₆ x 23⁵/₈
 30,5x61 fondo 8BF0836
 30x60 fondo rett. 8BF0863

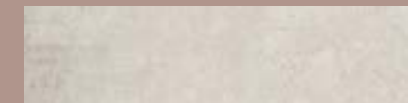

15x60 / 5⁷/₈ x 23⁵/₈
 fondo 8BF0865

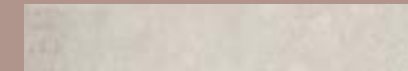

10x60 / 3¹⁵/₁₆ x 23⁵/₈
 fondo 8BF0816



5x60 / 1¹⁵/₁₆ x 23⁵/₈
 fondo 8BF0856



7,5x61 - 7,5x60
 2¹⁵/₁₆ x 24³/₁₆ - 2¹⁵/₁₆ x 23⁵/₈
 battiscopa 8BD08BA
 battiscopa rett. 8BD08BA/R



L 19,5 / 7¹¹/₁₆
 Esagona in tinta
 8BFIOES



L 19,5 / 7¹¹/₁₆
 Esagona Fiore a rilievo
 8BFIOEF



35x35 - 13³/₄ x 13³/₄
 fondo 8BFIO35



17,25x35 / 6¹³/₁₆ x 13³/₄
 fondo 8BFIO13



17,25x17,25 /
 6¹³/₁₆ x 6¹³/₁₆
 fondo 8BFIO17



L 19,5 / 7¹¹/₁₆
 Esagona in tinta
 8BF08ES



L 19,5 / 7¹¹/₁₆
 Esagona Fiore a rilievo
 8BF08EF



35x35 - 13³/₄ x 13³/₄
 fondo 8BF0835

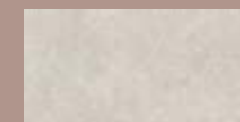

17,25x35 / 6¹³/₁₆ x 13³/₄
 fondo 8BF0813



17,25x17,25 /
 6¹³/₁₆ x 6¹³/₁₆
 fondo 8BF0817

GREY (06) FORMATI / SIZES

Gres Porcellanato / Porcelain Tiles 10 mm



92x92 - 90x90 / 36¹¹/₁₆ x 36¹¹/₁₆ - 35⁷/₁₆ x 35⁷/₁₆
 92x92 fondo 8BF0692
 90x90 fondo rett. 8BF0690
 90x90 fondo rigatino rett. 8BF0690/G



46x92 - 45x90
 18¹/₈ x 36¹/₄ - 17¹¹/₁₆ x 35⁷/₁₆
 46x92 fondo 8BF0642
 45x90 f. rett. 8BF0649
 45x90 f. rigatino rett. 8BF0649/G



30x90
 1¹³/₁₆ x 35⁷/₁₆
 fondo rett. 8BF0639
 f. rigatino rett. 8BF0639/G



22,5x90
 8⁷/₈ x 35⁷/₁₆
 fondo rett. 8BF0629
 f. rigatino rett. 8BF0629/G



61x61 - 60x60
 24³/₁₆ x 24³/₁₆ - 23⁵/₈ x 23⁵/₈
 fondo 8BF0661
 fondo rett. 8BF0660



30,5x61 - 30x60
 12¹/₂ x 24³/₁₆
 11¹³/₁₆ x 23⁵/₈
 30,5x61 fondo 8BF0636
 30x60 fondo rett. 8BF0663



15x60 / 5⁷/₈ x 23⁵/₈
 fondo 8BF0665



10x60 / 3¹⁵/₁₆ x 23⁵/₈
 fondo 8BF0616

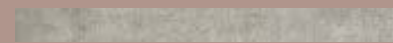

5x60 / 1¹⁵/₁₆ x 23⁵/₈
 fondo 8BF0656



7,5x61 - 7,5x60
 2¹⁵/₁₆ x 24³/₁₆ - 2¹⁵/₁₆ x 23⁵/₈
 battiscopa 8BD06BA
 battiscopa rett. 8BD06BA/R



L 19,5 / 7¹¹/₁₆
 Esagona in tinta
 8BF06ES



L 19,5 / 7¹¹/₁₆
 Esagona Fiore a rilievo
 8BF06EF



35x35 - 13³/₄ x 13³/₄
 fondo 8BF0635



17,25x35 / 6¹³/₁₆ x 13³/₄
 fondo 8BF0613



17,25x17,25 /
 6¹³/₁₆ x 6¹³/₁₆
 fondo 8BF0617

BLACK (14) FORMATI / SIZES

Gres Porcellanato / Porcelain Tiles 10 mm



92x92 - 90x90 / 36¹¹/₁₆ x 36¹¹/₁₆ - 35⁷/₁₆ x 35⁷/₁₆
 92x92 fondo 8BF1492
 90x90 fondo rett. 8BF1490
 90x90 fondo rigatino rett. 8BF1490/G



46x92 - 45x90
 18¹/₈ x 36¹/₄ - 17¹¹/₁₆ x 35⁷/₁₆
 46x92 fondo 8BF1442
 45x90 fondo rett. 8BF1449
 45x90 f. rigatino rett. 8BF1449/G



30x90
 1¹³/₁₆ x 35⁷/₁₆
 fondo rett. 8BF1439
 f. rigatino rett. 8BF1439/G



22,5x90
 8⁷/₈ x 35⁷/₁₆
 fondo rett. 8BF1429
 f. rigatino rett. 8BF1429/G



61x61 - 60x60
 24³/₁₆ x 24³/₁₆ - 23⁵/₈ x 23⁵/₈
 fondo 8BF1461
 fondo rett. 8BF1460



30,5x61 - 30x60
 12¹/₂ x 24³/₁₆
 11¹³/₁₆ x 23⁵/₈
 30,5x61 fondo 8BF1436
 30x60 fondo rett. 8BF1463



15x60 / 5⁷/₈ x 23⁵/₈
 fondo 8BF1465



10x60 / 3¹⁵/₁₆ x 23⁵/₈
 fondo 8BF1416



5x60 / 1¹⁵/₁₆ x 23⁵/₈
 fondo 8BF1456



7,5x61 - 7,5x60
 2¹⁵/₁₆ x 24³/₁₆ - 2¹⁵/₁₆ x 23⁵/₈
 battiscopa 8BD14BA
 battiscopa rett. 8BD14BA/R

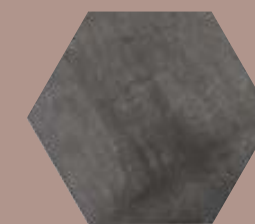

L 19,5 / 7¹¹/₁₆
 Esagona in tinta
 8BF14ES

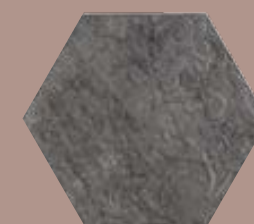

L 19,5 / 7¹¹/₁₆
 Esagona Fiore a rilievo
 8BF14EF

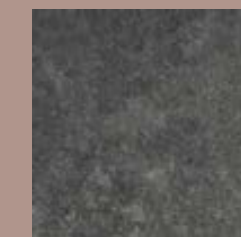

35x35 - 13³/₄ x 13³/₄
 fondo 8BF1435



17,25x35 / 6¹³/₁₆ x 13³/₄
 fondo 8BF1413



17,25x17,25 /
 6¹³/₁₆ x 6¹³/₁₆
 fondo 8BF1417

OLD COTTO (41) FORMATI / SIZES

Gres Porcellanato / Porcelain Tiles 10 mm



92x92 - 90x90 / 36¹¹/₁₆ x 36¹¹/₁₆ - 35⁷/₁₆ x 35⁷/₁₆
 92x92 fondo 8BF4192
 90x90 fondo rett. 8BF4190
 90x90 fondo rigatino rettificato 8BF4190/G



46x92 - 45x90
 18¹/₈ x 36¹/₄ - 17¹¹/₁₆ x 35⁷/₁₆
 46x92 fondo 8BF4142
 45x90 f. rett. 8BF4149
 45x90 f. rigatino rett. 8BF4149/G



30x90
 11¹³/₁₆ x 35⁷/₁₆
 fondo rett. 8BF4139
 f. rigatino rett. 8BF4139/G



22,5x90
 8⁷/₈ x 35⁷/₁₆
 fondo rett. 8BF4129
 f. rigatino rett. 8BF4129/G

SUNSET (SU) FORMATI / SIZES

Gres Porcellanato / Porcelain Tiles 10 mm



92x92 - 90x90 / 36¹¹/₁₆ x 36¹¹/₁₆ - 35⁷/₁₆ x 35⁷/₁₆
 92x92 fondo 8BFSU92
 90x90 fondo rett. 8BFSU90
 90x90 fondo rigatino rettificato 8BFSU90/G



46x92 - 45x90
 18¹/₈ x 36¹/₄ - 17¹¹/₁₆ x 35⁷/₁₆
 46x92 fondo 8BFSU42
 45x90 f. rett. 8BFSU49
 45x90 f. rigatino rett. 8BFSU49/G



30x90
 11¹³/₁₆ x 35⁷/₁₆
 fondo rett. 8BFSU39
 f. rigatino rett. 8BFSU39/G



22,5x90
 8⁷/₈ x 35⁷/₁₆
 fondo rett. 8BFSU29
 f. rigatino rett. 8BFSU29/G



61x61 - 60x60
 24³/₁₆ x 24³/₁₆ - 23⁵/₈ x 23⁵/₈
 fondo 8BF4161
 fondo rett. 8BF4160



30,5x61 - 30x60
 12¹/₂ x 24³/₁₆
 11¹³/₁₆ x 23⁵/₈
 30,5x61 fondo 8BF4136
 30x60 fondo rett. 8BF4163

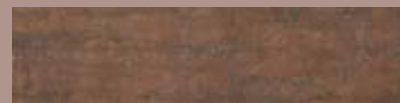

15x60 / 5⁷/₈ x 23⁵/₈
 fondo 8BF4165



10x60 / 3¹⁵/₁₆ x 23⁵/₈
 fondo 8BF4116



5x60 / 1¹⁵/₁₆ x 23⁵/₈
 fondo 8BF4156



7,5x61 - 7,5x60
 2¹⁵/₁₆ x 24³/₁₆ - 2¹⁵/₁₆ x 23⁵/₈
 battiscopa 8BD41BA
 battiscopa rett. 8BD41BA/R



61x61 - 60x60
 24³/₁₆ x 24³/₁₆ - 23⁵/₈ x 23⁵/₈
 fondo 8BFSU61
 fondo rett. 8BFSU60



30,5x61 - 30x60
 12¹/₂ x 24³/₁₆
 11¹³/₁₆ x 23⁵/₈
 30,5x61 fondo 8BFSU36
 30x60 fondo rett. 8BFSU63



15x60 / 5⁷/₈ x 23⁵/₈
 fondo 8BFSU65



10x60 / 3¹⁵/₁₆ x 23⁵/₈
 fondo 8BFSU16



5x60 / 1¹⁵/₁₆ x 23⁵/₈
 fondo 8BFSU56



7,5x61 - 7,5x60
 2¹⁵/₁₆ x 24³/₁₆ - 2¹⁵/₁₆ x 23⁵/₈
 battiscopa 8BDSUBA
 battiscopa rett. 8BDSUBA/R



L 19,5 / 7¹¹/₁₆
 Esagona in tinta 8BF41ES



L 19,5 / 7¹¹/₁₆
 Esagona Fiore a rilievo 8BF41EF



35x35 - 13³/₄ x 13³/₄
 fondo 8BF4135

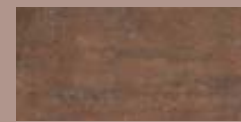

17,25x35 / 6¹³/₁₆ x 13³/₄
 fondo 8BF4113



17,25x17,25 / 6¹³/₁₆ x 6¹³/₁₆
 fondo 8BF4117



L 19,5 / 7¹¹/₁₆
 Esagona in tinta 8BFSUES



L 19,5 / 7¹¹/₁₆
 Esagona Fiore a rilievo 8BFSUEF



35x35 - 13³/₄ x 13³/₄
 fondo 8BFSU35



17,25x35 / 6¹³/₁₆ x 13³/₄
 fondo 8BFSU13



17,25x17,25 / 6¹³/₁₆ x 6¹³/₁₆
 fondo 8BFSU17

TORTORA (5E) FORMATI / SIZES

Gres Porcellanato / Porcelain Tiles 10 mm



92x92 - 90x90 / 36¹¹/₁₆ x 36¹¹/₁₆ - 35⁷/₁₆ x 35⁷/₁₆
 92x92 fondo 8BF5E92
 90x90 fondo rett. 8BF5E90
 90x90 fondo rigatino rettificato 8BF5E90/G



46x92 - 45x90
 18¹/₈ x 36¹/₄ - 17¹¹/₁₆ x 35⁷/₁₆
 46x92 fondo 8BF5E42
 45x90 f. rett. 8BF5E49
 45x90 f. rigatino rett. 8BF5E49/G



30x90
 11¹³/₁₆ x 35⁷/₁₆
 fondo rett. 8BF5E39
 f. rigatino rett. 8BF5E39/G



22,5x90
 8⁷/₈ x 35⁷/₁₆
 fondo rett. 8BF5E29
 f. rigatino rett. 8BF5E29/G



61x61 - 60x60
 24³/₁₆ x 24³/₁₆ - 23⁵/₈ x 23⁵/₈
 fondo 8BF5E61
 fondo rett. 8BF5E60



30,5x61 - 30x60
 12¹/₂ x 24³/₁₆
 11¹³/₁₆ x 23⁵/₈
 30,5x61 fondo 8BF5E36
 30x60 fondo rett. 8BF5E63



15x60 / 5⁷/₈ x 23⁵/₈
 fondo 8BF5E65



10x60 / 3¹⁵/₁₆ x 23⁵/₈
 fondo 8BF5E16

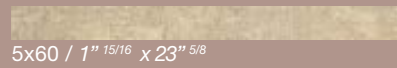

5x60 / 1¹⁵/₁₆ x 23⁵/₈
 fondo 8BF5E56



7,5x61 - 7,5x60
 2¹⁵/₁₆ x 24³/₁₆ - 2¹⁵/₁₆ x 23⁵/₈
 battiscopa 8BD5EBA
 battiscopa rett. 8BD5EBA/R



L 19,5 / 7¹¹/₁₆
 Esagona in tinta
 8BF5EES



L 19,5 / 7¹¹/₁₆
 Esagona Fiore a rilievo
 8BF5EEF



35x35 - 13³/₄ x 13³/₄
 fondo 8BF5E35

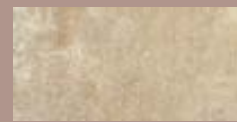

17,25x35 / 6¹³/₁₆ x 13³/₄
 fondo 8BF5E13



17,25x17,25 /
 6¹³/₁₆ x 6¹³/₁₆
 fondo 8BF5E17

DARK BROWN (8J) FORMATI / SIZES

Gres Porcellanato / Porcelain Tiles 10 mm



92x92 - 90x90 / 36¹¹/₁₆ x 36¹¹/₁₆ - 35⁷/₁₆ x 35⁷/₁₆
 92x92 fondo 8BF8J92
 90x90 fondo rett. 8BF8J90
 90x90 fondo rigatino rettificato 8BF8J90/G



46x92 - 45x90
 18¹/₈ x 36¹/₄ - 17¹¹/₁₆ x 35⁷/₁₆
 46x92 fondo 8BF8J42
 45x90 f. rett. 8BF8J49
 45x90 f. rigatino rett. 8BF8J49/G



30x90
 11¹³/₁₆ x 35⁷/₁₆
 fondo rett. 8BF8J39
 f. rigatino rett. 8BF8J39/G



22,5x90
 8⁷/₈ x 35⁷/₁₆
 fondo rett. 8BF8J29
 f. rigatino rett. 8BF8J29/G



61x61 - 60x60
 24³/₁₆ x 24³/₁₆ - 23⁵/₈ x 23⁵/₈
 fondo 8BF8J61
 fondo rett. 8BF8J60



30,5x61 - 30x60
 12¹/₂ x 24³/₁₆
 11¹³/₁₆ x 23⁵/₈
 30,5x61 fondo 8BF8J36
 30x60 fondo rett. 8BF8J63

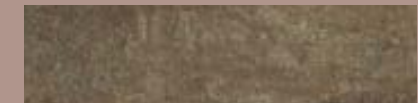

15x60 / 5⁷/₈ x 23⁵/₈
 fondo 8BF8J65



10x60 / 3¹⁵/₁₆ x 23⁵/₈
 fondo 8BF8J16



5x60 / 1¹⁵/₁₆ x 23⁵/₈
 fondo 8BF8J56



7,5x61 - 7,5x60
 2¹⁵/₁₆ x 24³/₁₆ - 2¹⁵/₁₆ x 23⁵/₈
 battiscopa 8BD8JBA
 battiscopa rett. 8BD8JBA/R

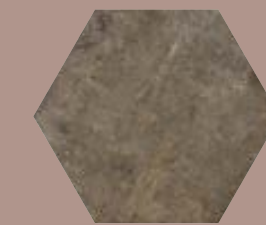

L 19,5 / 7¹¹/₁₆
 Esagona in tinta
 8BF8JES



L 19,5 / 7¹¹/₁₆
 Esagona Fiore a rilievo
 8BF8JEF



35x35 - 13³/₄ x 13³/₄
 fondo 8BF8J35



17,25x35 / 6¹³/₁₆ x 13³/₄
 fondo 8BF8J13



17,25x17,25 /
 6¹³/₁₆ x 6¹³/₁₆
 fondo 8BF8J17

GOLDEN (F7) FORMATI / SIZES

Gres Porcellanato / Porcelain Tiles 10 mm



92x92 - 90x90 / 36¹¹/₁₆ x 36¹¹/₁₆ - 35⁷/₁₆ x 35⁷/₁₆
 92x92 fondo 8BFF792
 90x90 fondo rett. 8BFF790
 90x90 fondo rigatino rettificato 8BFF790/G

46x92 - 45x90
 18¹/₈ x 36¹/₄ - 17¹¹/₁₆ x 35⁷/₁₆
 46x92 fondo 8BFF742
 45x90 f. rett. 8BFF749
 45x90 f. rigatino rett. 8BFF749/G

30x90
 11¹³/₁₆ x 35⁷/₁₆
 fondo rett. 8BFF739
 f. rigatino rett. 8BFF739/G

22,5x90
 8⁷/₈ x 35⁷/₁₆
 fondo rett. 8BFF729
 f. rigatino rett. 8BFF729/G

LIGHT BROWN (57) FORMATI / SIZES

Gres Porcellanato / Porcelain Tiles 10 mm



92x92 - 90x90 / 36¹¹/₁₆ x 36¹¹/₁₆ - 35⁷/₁₆ x 35⁷/₁₆
 92x92 fondo 8BF5792
 90x90 fondo rett. 8BF5790
 90x90 fondo rigatino rettificato 8BF5790/G

46x92 - 45x90
 18¹/₈ x 36¹/₄ - 17¹¹/₁₆ x 35⁷/₁₆
 46x92 fondo 8BF5742
 45x90 f. rett. 8BF5749
 45x90 f. rigatino rett. 8BF5749/G

30x90
 11¹³/₁₆ x 35⁷/₁₆
 fondo rett. 8BF5739
 f. rigatino rett. 8BF5739/G

22,5x90
 8⁷/₈ x 35⁷/₁₆
 fondo rett. 8BF5729
 f. rigatino rett. 8BF5729/G



61x61 - 60x60
 24³/₁₆ x 24³/₁₆ - 23⁵/₈ x 23⁵/₈
 fondo 8BFF761
 fondo rett. 8BFF760



30,5x61 - 30x60
 12¹/₂ x 24³/₁₆
 11¹³/₁₆ x 23⁵/₈
 30,5x61 fondo 8BFF736
 30x60 fondo rett. 8BFF763

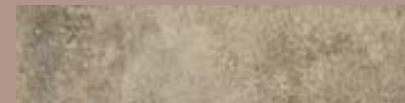

15x60 / 5⁷/₈ x 23⁵/₈
 fondo 8BFF765



10x60 / 3¹⁵/₁₆ x 23⁵/₈
 fondo 8BFF716



5x60 / 1¹⁵/₁₆ x 23⁵/₈
 fondo 8BFF756



7,5x61 - 7,5x60
 2¹⁵/₁₆ x 24³/₁₆ - 2¹⁵/₁₆ x 23⁵/₈
 battiscopa 8BDF7BA
 battiscopa rett. 8BDF7BA/R



L 19,5 / 7¹¹/₁₆
 Esagona in tinta
 8BFF7ES



L 19,5 / 7¹¹/₁₆
 Esagona Fiore a rilievo
 8BFF7EF



35x35 - 13³/₄ x 13³/₄
 fondo 8BFF735



17,25x35 / 6¹³/₁₆ x 13³/₄
 fondo 8BFF713



17,25x17,25 /
 6¹³/₁₆ x 6¹³/₁₆
 fondo 8BFF717



61x61 - 60x60
 24³/₁₆ x 24³/₁₆ - 23⁵/₈ x 23⁵/₈
 fondo 8BF5761
 fondo rett. 8BF5760

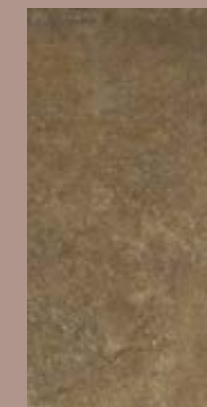

30,5x61 - 30x60
 12¹/₂ x 24³/₁₆
 11¹³/₁₆ x 23⁵/₈
 30,5x61 fondo 8BF5736
 30x60 fondo rett. 8BF5763

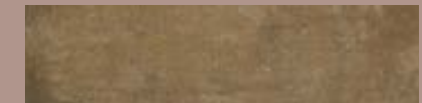

15x60 / 5⁷/₈ x 23⁵/₈
 fondo 8BF5765

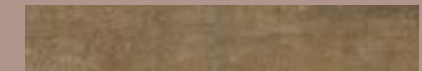

10x60 / 3¹⁵/₁₆ x 23⁵/₈
 fondo 8BF5716



5x60 / 1¹⁵/₁₆ x 23⁵/₈
 fondo 8BF5756



7,5x61 - 7,5x60
 2¹⁵/₁₆ x 24³/₁₆ - 2¹⁵/₁₆ x 23⁵/₈
 battiscopa 8BD57BA
 battiscopa rett. 8BD57BA/R



L 19,5 / 7¹¹/₁₆
 Esagona in tinta
 8BF57ES

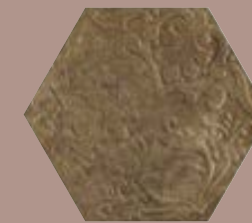

L 19,5 / 7¹¹/₁₆
 Esagona Fiore a rilievo
 8BF57EF



35x35 - 13³/₄ x 13³/₄
 fondo 8BF5735



17,25x35 / 6¹³/₁₆ x 13³/₄
 fondo 8BF5713



17,25x17,25 /
 6¹³/₁₆ x 6¹³/₁₆
 fondo 8BF5717

<p>92x92 - 90x90 36¹/₄ x 36¹/₄ - 35⁷/₁₆ 35⁷/₁₆ x 35⁷/₁₆</p>  <p>ANTHRACITE</p> <p>f. compact 8AFIO92 f. compact rett. 8AFIO90/R</p>	<p>45x90 17¹¹/₁₆ x 35⁷/₁₆</p>  <p>WHITE</p> <p>f. compact rett.8AFIO49/R</p>	<p>30x90 11¹³/₁₆ x 35⁷/₁₆</p>  <p>GREY</p> <p>f. compact rett. 8AFIO39/R</p>	<p>92x92 - 90x90 36¹/₄ x 36¹/₄ - 35⁷/₁₆ 35⁷/₁₆ x 35⁷/₁₆</p>  <p>WHITE</p> <p>f. compact 8AF0892 f. compact rett. 8AF0890/R</p>	<p>45x90 17¹¹/₁₆ x 35⁷/₁₆</p>  <p>WHITE</p> <p>f. compact rett.8AF0849/R</p>	<p>30x90 11¹³/₁₆ x 35⁷/₁₆</p>  <p>WHITE</p> <p>f. compact rett. 8AF0839/R</p>
 <p>GREY</p> <p>f. compact 8AF0692 f. compact rett. 8AF0690/R</p>	 <p>WHITE</p> <p>f. compact rett.8AF0649/R</p>	 <p>GREY</p> <p>f. compact rett. 8AF0639/R</p>	 <p>BLACK</p> <p>f. compact 8AF1492 f. compact rett. 8AF1490/R</p>	 <p>BLACK</p> <p>f. compact rett.8AF1449/R</p>	 <p>BLACK</p> <p>f. compact rett. 8AF1439/R</p>
 <p>OLD COTTO</p> <p>f. compact 8AF4192 f. compact rett. 8AF4190/R</p>	 <p>OLD COTTO</p> <p>f. compact rett.8AF4149/R</p>	 <p>OLD COTTO</p> <p>f. compact rett. 8AF4139/R</p>	 <p>SUNSET</p> <p>f. compact 8AFSU92 f. compact rett. 8AFSU90/R</p>	 <p>SUNSET</p> <p>f. compact rett.8AFSU49/R</p>	 <p>SUNSET</p> <p>f. compact rett. 8AFSU39/R</p>
 <p>TORTORA</p> <p>f. compact 8AF5E92 f. compact rett. 8AF5E90/R</p>	 <p>TORTORA</p> <p>f. compact rett.8AF5E49/R</p>	 <p>TORTORA</p> <p>f. compact rett. 8AF5E39/R</p>	 <p>DARK BROWN</p> <p>f. compact 8AF8J92 f. compact rett. 8AF8J90/R</p>	 <p>DARK BROWN</p> <p>f. compact rett.8AF8J49/R</p>	 <p>DARK BROWN</p> <p>f. compact rett. 8AF8J39/R</p>
 <p>GOLDEN</p> <p>f. compact 8AFF792 f. compact rett. 8AFF790/R</p>	 <p>GOLDEN</p> <p>f. compact rett.8AFF749/R</p>	 <p>GOLDEN</p> <p>f. compact rett. 8AFF739/R</p>	 <p>LIGHT BROWN</p> <p>f. compact 8AF5792 f. compact rett. 8AF5790/R</p>	 <p>LIGHT BROWN</p> <p>f. compact rett.8AF5749/R</p>	 <p>LIGHT BROWN</p> <p>f. compact rett. 8AF5739/R</p>

<p>ANTHRACITE</p>  <p>61x61 - 60x60 24³/₁₆ x 24³/₁₆ - 23⁵/₈ x 23⁵/₈ fondo compact 8AFIO61 fondo compact rett. 8AFIO60/R</p>	<p>WHITE</p>  <p>61x61 - 60x60 24³/₁₆ x 24³/₁₆ - 23⁵/₈ x 23⁵/₈ fondo compact 8AF0861 fondo compact rett. 8AF0860/R</p>	<p>GREY</p>  <p>61x61 - 60x60 24³/₁₆ x 24³/₁₆ - 23⁵/₈ x 23⁵/₈ fondo compact 8AF0661 fondo compact rett. 8AF0660/R</p>	<p>BLACK</p>  <p>61x61 - 60x60 24³/₁₆ x 24³/₁₆ - 23⁵/₈ x 23⁵/₈ fondo compact 8AF1461 fondo compact rett. 8AF1460/R</p>	<p>OLD COTTO</p>  <p>61x61 - 60x60 24³/₁₆ x 24³/₁₆ - 23⁵/₈ x 23⁵/₈ fondo compact 8AF4161 fondo compact rett. 8AF4160/R</p>
<p>LIGHT BROWN</p>  <p>61x61 - 60x60 24³/₁₆ x 24³/₁₆ - 23⁵/₈ x 23⁵/₈ fondo compact 8AF5761 fondo compact rett. 8AF5760/R</p>	<p>TORTORA</p>  <p>61x61 - 60x60 24³/₁₆ x 24³/₁₆ - 23⁵/₈ x 23⁵/₈ fondo compact 8AF5E61 fondo compact rett. 8AF5E60/R</p>	<p>DARK BROWN</p>  <p>61x61 - 60x60 24³/₁₆ x 24³/₁₆ - 23⁵/₈ x 23⁵/₈ fondo compact 8AF8J61 fondo compact rett. 8AF8J60/R</p>	<p>GOLDEN</p>  <p>61x61 - 60x60 24³/₁₆ x 24³/₁₆ - 23⁵/₈ x 23⁵/₈ fondo compact 8AFF761 fondo compact rett. 8AFF760/R</p>	<p>SUNSET</p>  <p>61x61 - 60x60 24³/₁₆ x 24³/₁₆ - 23⁵/₈ x 23⁵/₈ fondo compact 8AFSU61 fondo compact rett. 8AFSU60/R</p>

APOGEO14 PEZZI SPECIALI/SPECIAL PIECES compact 20 mm

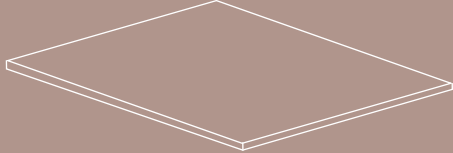
 <p>17x61 / 6¹¹/₁₆ x 24³/₁₆ stone edge (swimming pool edge-bordo piscina) 8AD**SE</p>	 <p>61x61 / 24³/₁₆ x 24³/₁₆ Gradino bull nose 1 lato 8AD**B1 61x61 / 24³/₁₆ x 24³/₁₆ Ang. Gradino bull nose 2 lati 8AD** B2</p>
---	---

- Old Cotto (41)
- Anthracite (10)
- Black (14)
- Tortora (5E)
- White(08)
- Grey (06)
- Sunset(SU)
- Golden(F7)
- Dark Brown (8J)
- Light Brown (57)

 <p>61x61 corner grid sx 8AD**SC 24³/₁₆ x 24³/₁₆</p>	 <p>61x61 corner grid dx 8AD**DC 24³/₁₆ x 24³/₁₆</p>	 <p>61x61 stone grid 8AD**SG 24³/₁₆ x 24³/₁₆</p>	 <p>20x51 curved joint 8AD**CJ 8¹/₁₆ x 20³/₈</p>	 <p>20x51 curver drip joint 8AD**CD 8¹/₁₆ x 20³/₈</p>	
 <p>61x61 quarter grid sx 8AD**QS 24³/₁₆ x 24³/₁₆</p>	 <p>61x61 quarter grid dx 8AD**QD 24³/₁₆ x 24³/₁₆</p>	 <p>20x30 stone drip 8AD**SD 8¹/₁₆ x 11³/₁₆</p>	 <p>20x30 linear joint 8AD**LJ 8¹/₁₆ x 11³/₁₆</p>	 <p>20x20 quarter drip 8AD**QP 8¹/₁₆ x 8¹/₁₆</p>	 <p>20x20 square joint 8AD**SJ 8¹/₁₆ x 8¹/₁₆</p>

PACKING LIST

Imballaggi / Packing / Verpackung / Emballage / Упаковочный список / 包装

Formato	Denominazione	Spessore	PZ/PAC	MQ/PAC	KG/PAC	PAC/PAL	MQ/PAL	KG/PAL
Size	Description	Thickness	PCS/PACK	SQM/PACK	KG/PACK	PACK/PAL	SQM/PAL	KG/PAL
Format	Bezeichnung	Stärke	STK/KAR	QM/KAR	KG/KAR	KAR/PAL	QM/PAL	KG/PAL
Format	Description	Epaisseur	PCS/PAQUET	MQ/PAQUET	KG/PAQUET	PAQ/PAL	MQ/PAL	KG/PAL
Размер	Наименование	Толщина	шт./коробка	MQ/упаковка	КГ/упаковка	коробка/паллет	MQ/паллета	КГ/паллета
规格	名称	厚度	片/包	平方米/包	公斤/包	包/PAL	平方米/PAL	公斤/PAL

Gres porcellanato ad alto spessore 18mm - 20 mm / Porcelain tiles 18mm - 20 mm thickness
Feinsteinzeug mit einer Stärke von 18mm - 20 mm / Grès cérame de forte épaisseur 18mm - 20 mm
керамогранит с высокой толщиной 18mm - 20 mm / 18 - 20 毫米高厚上釉整体砂岩

92x92	36 ¹¹ / ₁₆ x 36 ¹¹ / ₁₆	fondo	18	1	0,8464	34,87	32	27,08	1150
90x90	35 ⁷ / ₁₆ x 35 ⁷ / ₁₆	fondo rett.	18	1	0,8100	33,37	32	25,92	1100
45x90	17 ¹¹ / ₁₆ x 35 ⁷ / ₁₆	fondo rett.	18	2	0,8100	33,37	32	25,92	1100
30x90	11 ¹³ / ₁₆ x 35 ⁷ / ₁₆	fondo rett.	18	3	0,8100	33,37	32	25,92	1100
61x61	24 ³ / ₁₆ x 24 ³ / ₁₆	fondo	20	2	0,7442	31,00	32	23,81	1025
60x60	23 ⁵ / ₈ x 23 ⁵ / ₈	fondo rett.	20	2	0,7200	30,00	32	23,04	990
61x61	24 ³ / ₁₆ x 24 ³ / ₁₆	stone grid	20	2	0,7442	31,20	32	23,81	1030
61x61	24 ³ / ₁₆ x 24 ³ / ₁₆	quarter grid	20	2	0,7154	30,00	32	22,89	990
61x61	24 ³ / ₁₆ x 24 ³ / ₁₆	corner grid	20	2	0,7380	30,94	32	23,62	1025
20x51	8 ¹¹ / ₁₆ x 20 ³ / ₈	curved joint (r=51)	20	10	1,2880	28,55	***	***	***
20x51	8 ¹¹ / ₁₆ x 20 ³ / ₈	curved drip joint (r=51)	20	10	1,2880	28,20	***	***	***
20x30	8 ¹¹ / ₁₆ x 11 ³ / ₁₆	stone drip	20	8	0,4800	16,80	***	***	***
20x30	8 ¹¹ / ₁₆ x 11 ³ / ₁₆	linear joint	20	8	0,4800	16,90	***	***	***
20x20	8 ¹¹ / ₁₆ x 8 ¹¹ / ₁₆	square joint	20	12	0,4800	17,50	***	***	***
20x20	8 ¹¹ / ₁₆ x 8 ¹¹ / ₁₆	quarter drip	20	12	0,4800	17,20	***	***	***

17x61	6 ¹¹ / ₁₆ x 24 ³ / ₁₆	stone edge	20	4	0,4148	25,6	***	***	***
61x61	24 ³ / ₁₆ x 24 ³ / ₁₆	gradino bull nose 1/2l	20	2	0,7442	31,00	***	***	***

Gres porcellanato ad alto spessore 10 mm / Porcelain tiles 10 mm thickness
Feinsteinzeug mit einer Stärke von 10 mm / Grès cérame de forte épaisseur 10 mm
керамогранит с высокой толщиной 10 mm / 10 毫米高厚上釉整体砂岩

92x92	36 ¹¹ / ₁₆ x 36 ¹¹ / ₁₆	fondo	10	2	1,6928	40,80	32	54,17	1340
46x92	18 ¹ / ₈ x 36 ¹¹ / ₁₆	fondo	10	3	1,2696	30,60	32	40,63	1010
61x61	24 ³ / ₁₆ x 24 ³ / ₁₆	fondo	10	3	1,1163	26,90	40	44,65	1110
30,5x61	12 ¹ / ₂ x 24 ³ / ₁₆	fondo	10	7	1,3027	31,40	40	52,11	1290
90x90	35 ⁷ / ₁₆ x 35 ⁷ / ₁₆	fondo rett.	10	2	1,6200	39,04	32	51,84	1280
45x90	17 ¹¹ / ₁₆ x 35 ⁷ / ₁₆	fondo rett.	10	3	1,2150	29,28	32	38,88	970
22,5x90	8 ¹¹ / ₁₆ x 35 ⁷ / ₁₆	fondo rett.	10	6	1,2150	29,28	32	38,88	970
30x90	11 ¹³ / ₁₆ x 35 ⁷ / ₁₆	fondo rett.	10	4	1,0800	26,03	40	43,20	1075
60x60	23 ⁵ / ₈ x 23 ⁵ / ₈	fondo rett.	10	3	1,0800	26,03	40	43,20	1075
30x60	11 ¹³ / ₁₆ x 23 ⁵ / ₈	fondo rett.	10	7	1,2600	30,37	40	50,40	1245

15x60	5 ⁷ / ₈ x 23 ⁵ / ₈	fondo	10	14	1,2600	30,37	40	50,40	1245
10x60	3 ¹⁵ / ₁₆ x 23 ⁵ / ₈	fondo	10	18	1,0800	26,03	40	43,20	1075
5x60	1 ¹⁵ / ₁₆ x 23 ⁵ / ₈	fondo	10	40	1,2000	28,92	40	48,00	1190

L.19,5	7 ¹¹ / ₁₆	esagona fondo e decoro	10	12	1,1856	25,56	30	35,57	800
--------	---------------------------------	------------------------	----	----	--------	-------	----	-------	-----

35x35	13 ³ / ₄ x 13 ³ / ₄	fondo e decoro	10	11	1,3475	28,30	40	53,90	1160
17,25x35	6 ¹³ / ₁₆ x 13 ³ / ₄	fondo e decoro	10	19	1,1476	24,56	44	50,49	1110
17,25x17,25	6 ¹³ / ₁₆ x 6 ¹³ / ₁₆	fondo e decoro	10	25	0,7450	15,94	80	59,60	1305

7,5x61	2 ¹⁵ / ₁₆ x 24 ³ / ₁₆	battiscopa	10	28	17,08 m/lin	29,23	40	683,2 m/lin	1200
7,5x60	2 ¹⁵ / ₁₆ x 23 ⁵ / ₈	battiscopa	10	28	16,08 m/lin	28,35	40	672 m/lin	1165

Per motivi tecnici i pesi sopra indicati possono variare +/- del 4 %.

Die oben angegebenen Gewichte können sich aus technischen Gründen um +/- 4% ändern.







The above mentioned weights may change for technical reasons for +/- 4%.

Pour des motifs techniques les poids au-dessus mentionnés peuvent changer de +/- 4%.







Los pesos anteriormente mencionados pueden cambiar por razones técnicas de +/- 4%.

По понятным техническим причинам выше указанная нагрузка веса может изменяться от + 4 % до - 4%./ 由于技术原因, 权重可能会有所差别, 正负可相差4%左右

CARATTERISTICHE TECNICHE - TECHNICAL CHARACTERISTICS - CARACTÉRISTIQUES TECHNIQUES TECHNISCHE KENNZEICHEN - ТЕХНИЧЕСКИЕ ХАРАКТЕРИСТИКИ - 技术属性

Formati Sizes								
	Sizes	GL-UGL	GL-UGL	GL-UGL	GL-UGL	GL-UGL	GL-UGL	
	Spessore Thickness Epaisseur Stärke Толщина 厚度	Assorbimento acqua Water absorption Absorption d'eau Wasseraufnahme Водопоглощаемость 吸水性	Resistenza al gelo Frost resistance Résistance au gel Frostbeständigkeit Морозостойчивость 耐寒性	Resistenza alla flessione Bending strenght Rés. au poinçonnement statique Biegefestigkeit Прочностьприизгибе 抗弯强度	Carico di rottura medio Breakage load Charge de rupture Bruchlast Средняя разрушающая нагрузка 张强抗性	Carico statico Static load Charge statique Statische Belastung Статическая нагрузка 静载荷	Durezza superficiale Scratch resistance Dureté superficielle Oberflächenhärte Твердостьповерхности 表面硬度	
mm	ISO 10545-3 Classe B1a ASTM C 373 (E<=0,5%)	EN 202 ISO 10545-12 ASTM C 1026	ISO 10545-4	ASTM C 648	ISO 10545-4	BREAKING LOAD CLASS (EN 1339-2003)	EN 12825	EN 101 MOHS

61x61 f. compact 60x60 f. compact	20 mm	≤ 0,2%	ingelivo, frostresistent, frostbeständig, ingelif, морозостойкие	N/mm²>54	conforme compliant gemäß совместимый	F carico di rottura medio (N) >12000 S sforzo rottura medio (N) >11800 R resistenza flessione media N/mm² > 54	T 11	5KN Classe 1 Class 1 Classe 1 Класс 1	8
92x92 f. comp. 90x90 f. comp. rett.	18 mm	≤ 0,2%	ingelivo, frostresistent, frostbeständig, ingelif, морозостойкие	N/mm²>48	conforme compliant gemäß совместимый	F carico di rottura medio (N) > 8000 S sforzo rottura medio (N) > 8300 R resistenza flessione media N/mm² > 48			8
45x90 f. comp. rett.	18 mm	≤ 0,2%	ingelivo, frostresistent, frostbeständig, ingelif, морозостойкие	N/mm²>48	conforme compliant gemäß совместимый	F carico di rottura medio (N) > 4000 S sforzo rottura medio (N) > 8300 R resistenza flessione media N/mm² > 48			8
30x90 f. comp. rett.	18 mm	≤ 0,2%	ingelivo, frostresistent, frostbeständig, ingelif, морозостойкие	conforme compliant gemäß совместимый	conforme compliant gemäß совместимый	conforme compliant gemäß совместимый			8
tutti i formati all sizes	10 mm	≤ 0,2%	ingelivo, frostresistent, frostbeständig, ingelif, морозостойкие	conforme - compliant gemäß - совместимый	conforme compliant gemäß совместимый	conforme - compliant gemäß - совместимый			8

Formati Sizes									
	GL-UGL	GL-UGL	GL-UGL	GL-UGL	GL-UGL	GL	GL-UGL		
	Spessore Thickness Epaisseur Stärke Толщина 厚度	Resistenza alla macchia Stain resistance Résistance à la tache Fleckenbeständigkeit Устойчивостьк пятнообразованию 抗污性	Resistenza agli agenti chimici Chemical resistance Résistance chimique Chemische beständigkeit Химическая стойкость 化学反应物抗性	Resistenza allo scivolamento Anti-slip Anti-gissant Rutschhemmend Сопротивление скольжению 抗打滑性	Test scivolamento a piede nudo su superficie bagnata Barefoot slip on wet surface Glissement à pied nu sur sol mouillé Rutschhemmung: Anforderungen an Bodenbelägen in nassbelasteten Barfußbereichen Тест скольжения ногой по влажной поверхности 湿表面裸足打滑测	Resist. Abrasione Abrasion resistance Résistance à l'abrasion Abriebfestigkeit Устойчивостьк истиранию 抗磨损强度	** Resistenza al sale Salt resistant Résistance au sel Bestaändig gegen Salz Устойчивостьк воздействию солей 耐盐性		
mm	ISO 10545-14	ISO 10545-13 ASTM C 650	DIN 51130 R	Coefficiente d'attrito BCR TORTUS	ASTM C 1028 C.O.F	Coefficiente dinamico di attrito Dynamic coeff. of friction DCOF (BOT 3000) (section 9.6 ANSI A137.1 2012)	DIN 51097	EN 154 ISO 10545-7 ASTM C 1027 PEI	NaCl

61x61 f. compact 60x60 f. compact	20 mm	5	GA - GLA GHA	11	DRY> 0,40 WET> 0,40	DRY >0,70 WET >0,60	WET > 0,50	Classe A+B+C	IV	Resistente Resistant Résistant Gemäß
92x92 f. comp. 90x90 f. comp rett.	18 mm	5	GA - GLA GHA	11	DRY> 0,40 WET> 0,40	DRY >0,70 WET >0,60	WET > 0,50	Classe A+B+C	IV	Resistente Resistant Résistant Gemäß
45x90 f. comp. rett.	18 mm	5	GA - GLA GHA	11	DRY> 0,40 WET> 0,40	DRY >0,70 WET >0,60	WET > 0,50	Classe A+B+C	IV	Resistente Resistant Résistant Gemäß
30x90 f. comp rett.	18 mm	5	GA - GLA GHA	11	DRY> 0,40 WET> 0,40	DRY >0,70 WET >0,60	WET > 0,50	Classe A+B+C	IV	Resistente Resistant Résistant Gemäß
Tutti i formati All sizes	10 mm	5	GA - GLA GHA	10	DRY> 0,40 WET> 0,40	DRY >0,70 WET >0,60	WET > 0,50	Classe A+B+C	IV	Resistente Resistant Résistant Gemäß

**

Il sale lascia un residuo di colore bianco che viene eliminato con acqua dolce e spazzolone. Strofinare fino alla rimozione totale del residuo.

Salt leaves a residual of white colour that can be removed with fresh water and scrubbing brush. Scrub until the total removal of the residual.

Le sel laisse un résidu de couleur blanche qui s'élimine avec de l'eau douce et un balai-brosse. Frotter jusqu'à l'élimination totale du résidu.

Das Salz hinterlaesst einen Restbestand in weisser Farbe, welcher mit Suesswasser und einer Buerste entfernt werden kann. Solange Reiben bis Restbestand komplett entfernt ist.

Соль способствует образованию белого налета, который может быть удален при помощи пресной воды и щетки. Протереть до полного удаления налета

残留在瓷砖上的盐会留下白色的痕迹, 可用淡水和刷子清洗。使用刷子擦洗瓷砖直到痕迹完全消失。



www.tagina.it



Ceramics of Italy



MADE IN TAGINA

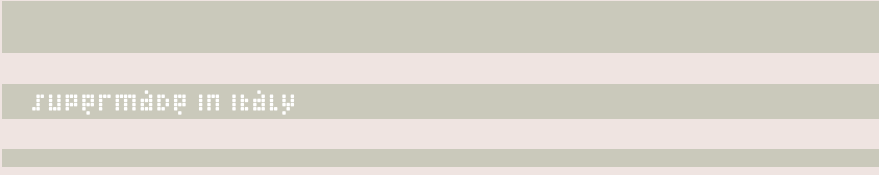

supermade in italy